

MODELO 1-1

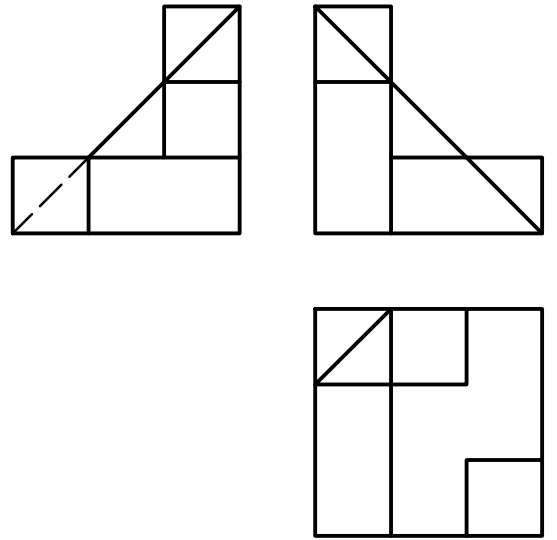

MODELO 1-2

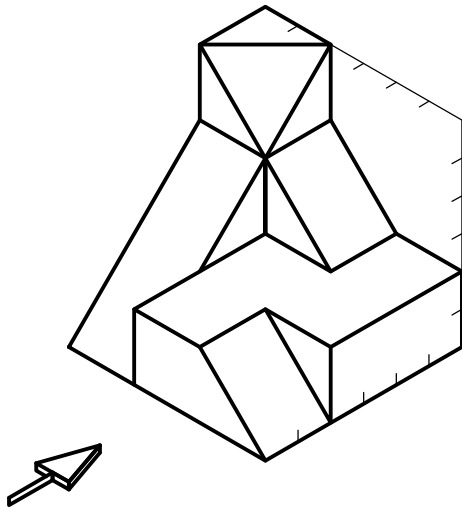
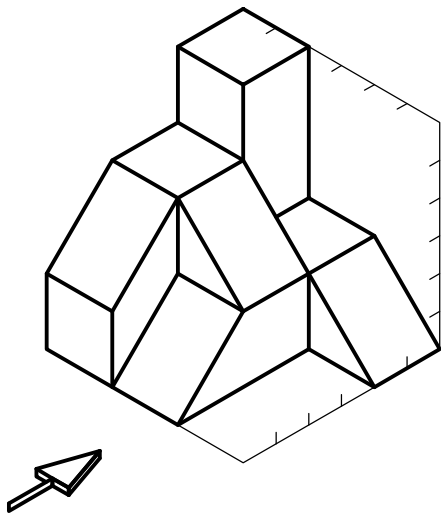
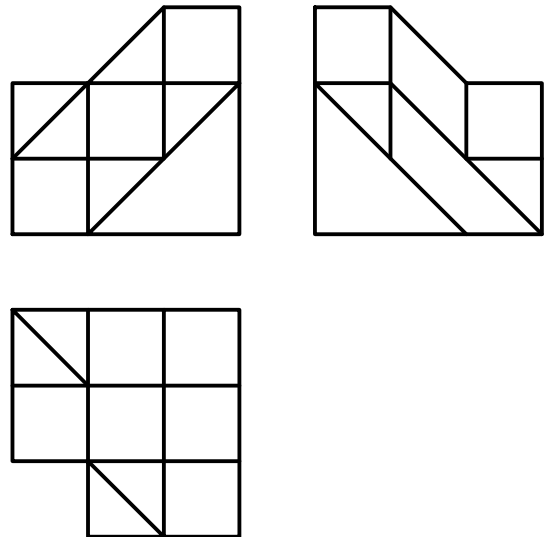
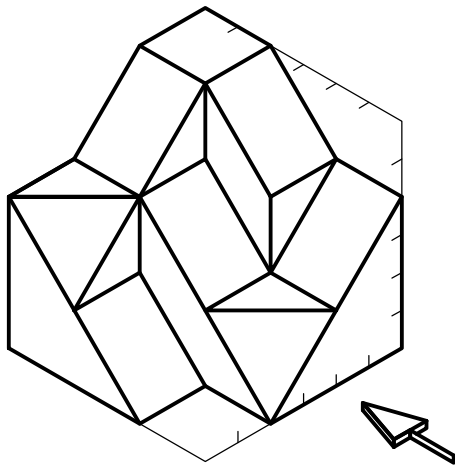

MODELO 1-3

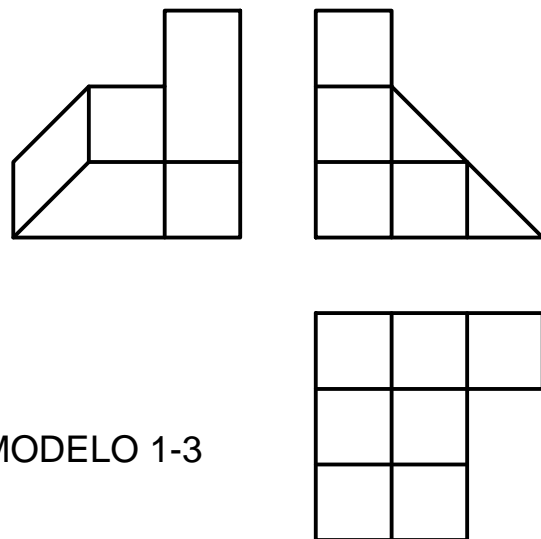

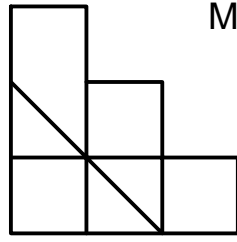
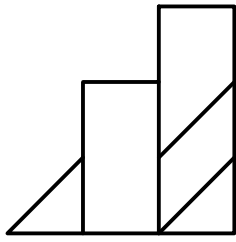

MODELO 1-4

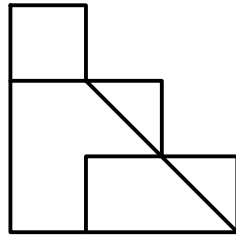
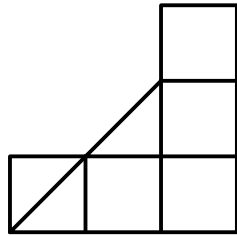
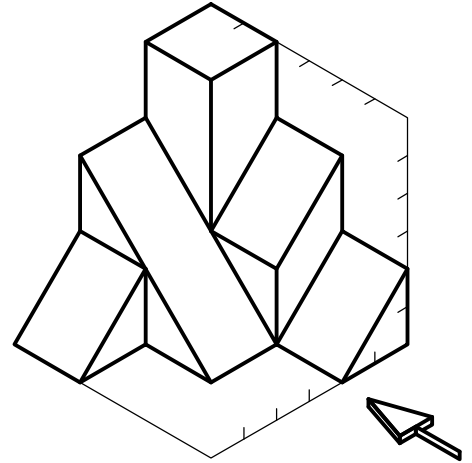
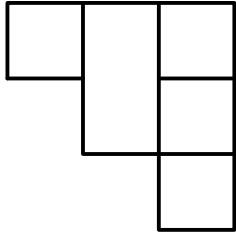

MODELO 1-5

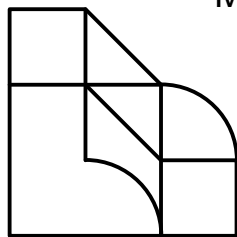
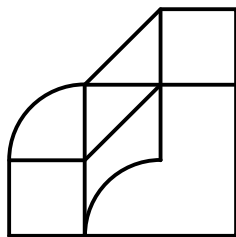
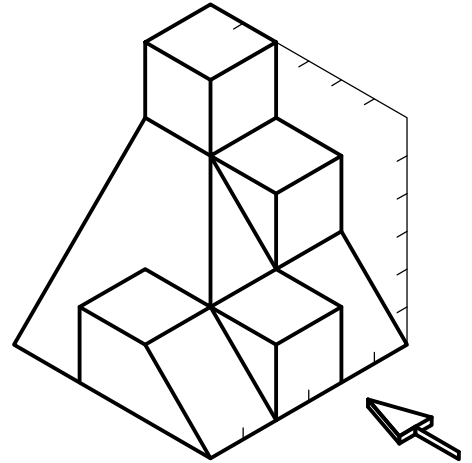
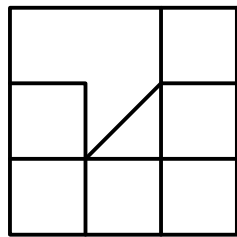

MODELO 1-7

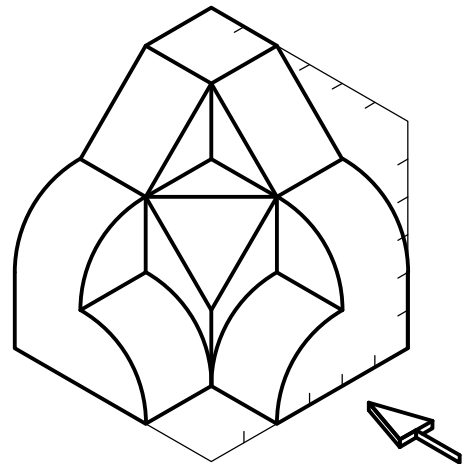
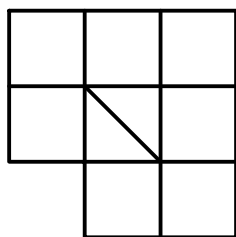

MODELO 1-8

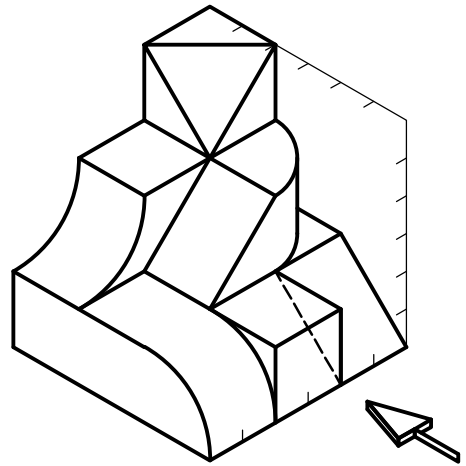
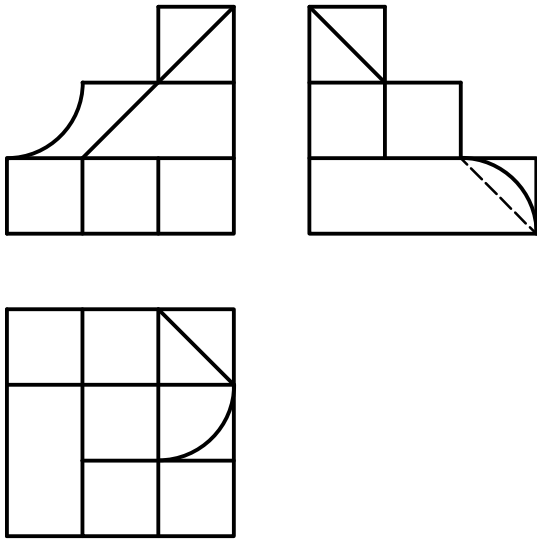

MODELO 1-9

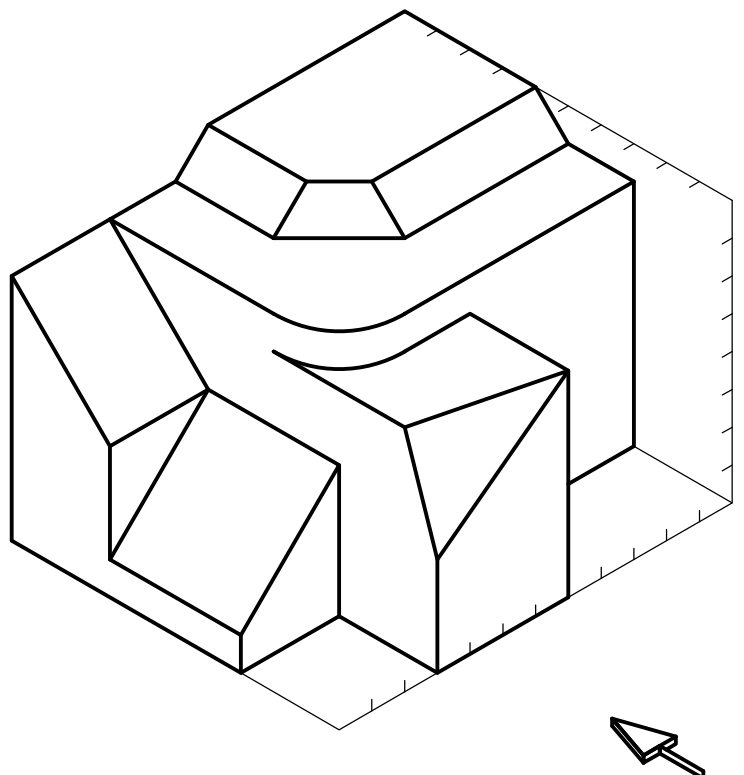
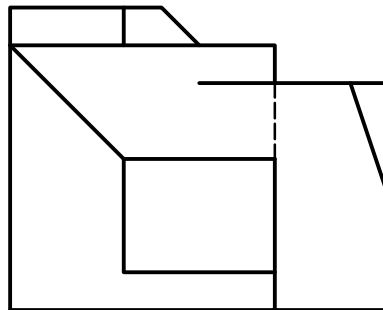
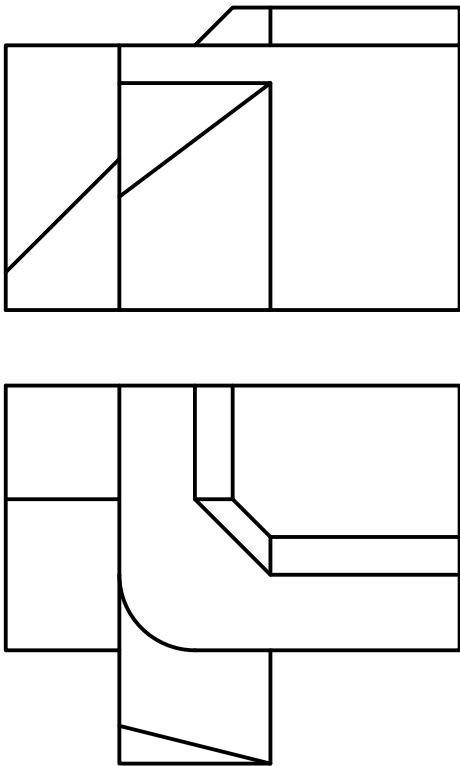

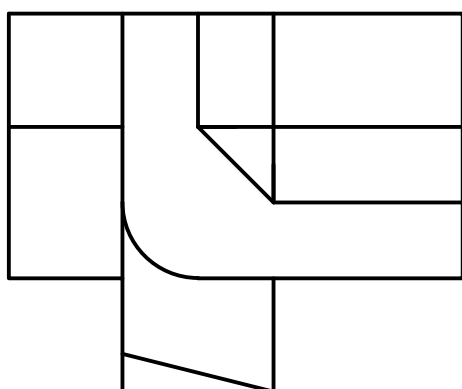
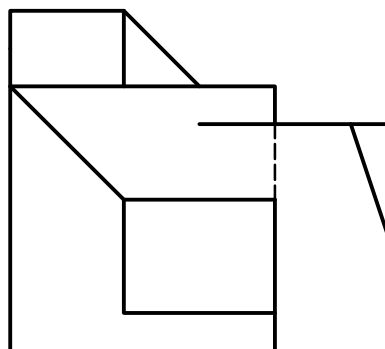
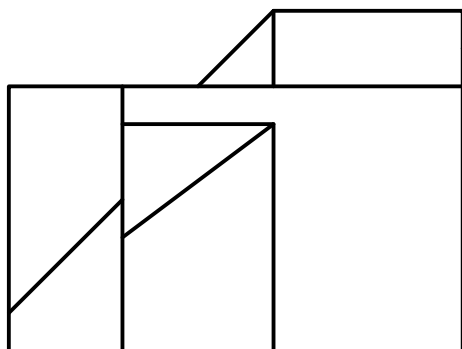

variante del modelo 1-9

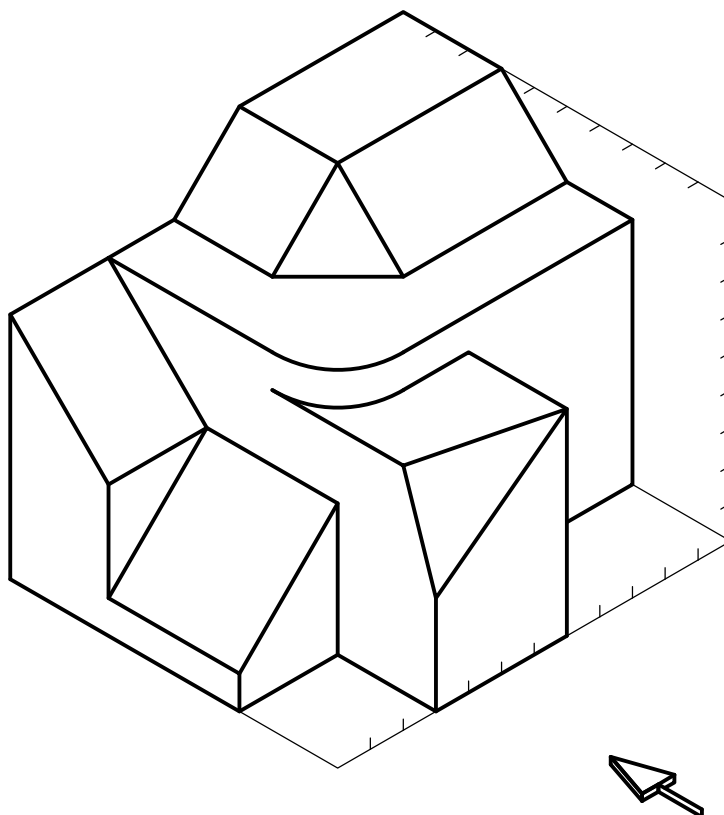

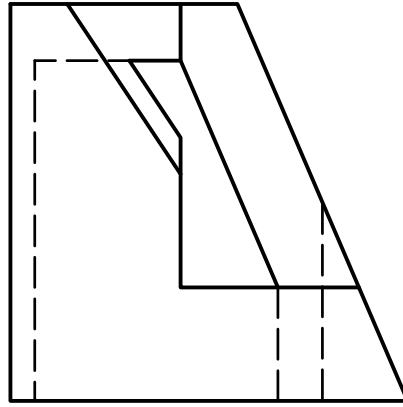
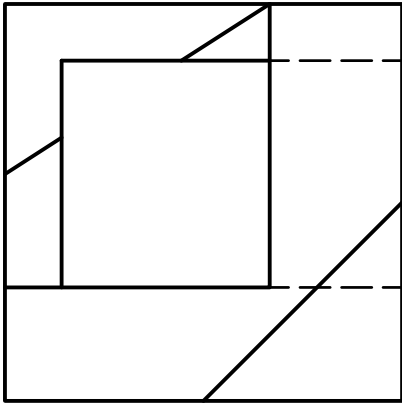

Modelo 1-6

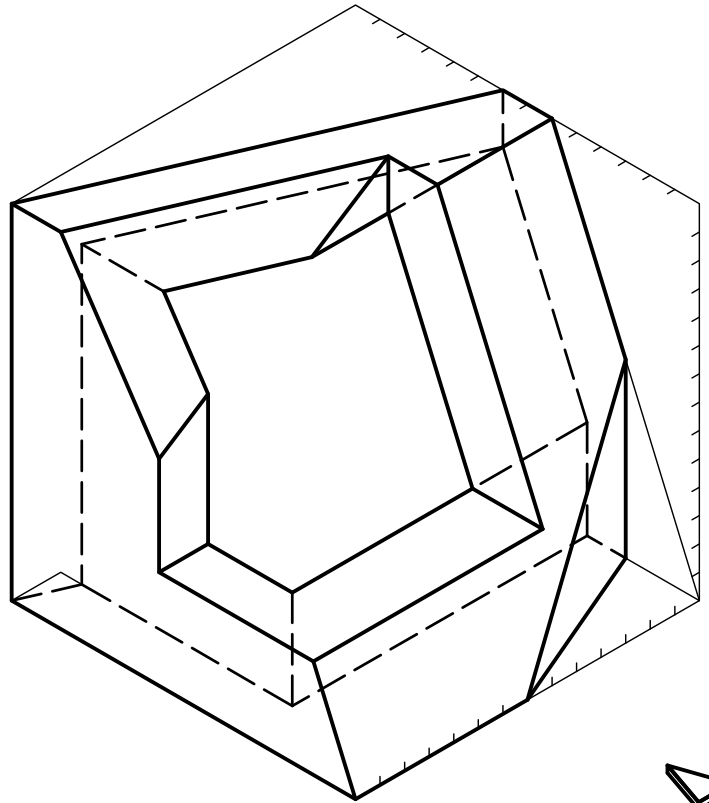
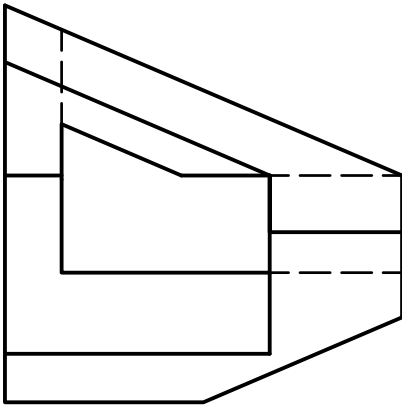

E 3:4

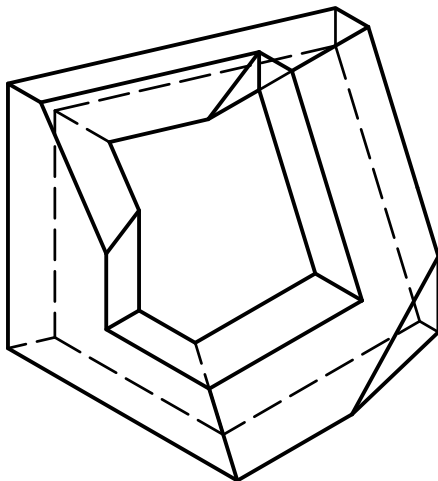

Si se varia la esquina inferior derecha, adelantándola, se tienen dos posibles variantes, según el dibujo mío, que es una interpretación, haciendo algunas variaciones importantes en la parte derecha de la pieza, respecto de la fotocopia facilitada.

